

Macromécanique

- **Micromécanique**
 - Lois des mélanges
 - Halpin-Tsai
 - Renforts discontinus
 - **Macromécanique**
 - Anisotropie
 - Comportement d'une strate
 - Composites orthotropes sous contraintes planes
 - Comportement des stratifiés, symétries
 - Résistance et critères de rupture
 - Endommagement et mécanique de la rupture
- Technologie des composites (Master)**
- Comportement des structures sandwich
 - Composites textiles
 - Fatigue, design industriel, etc...

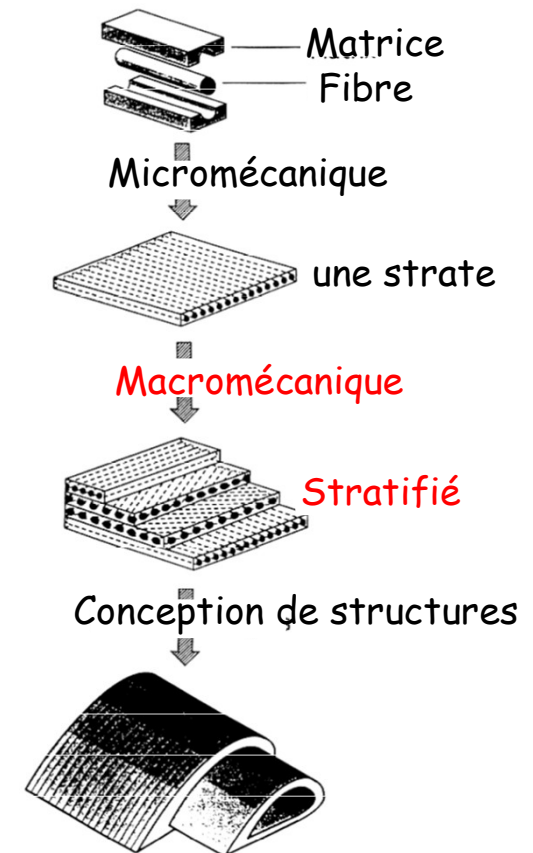

Anisotropie

Matériaux homo ou hétérogènes

P_1 ● P_2 ●

Matériaux iso ou anisotropes

P_1 ↗ P_2 ↘

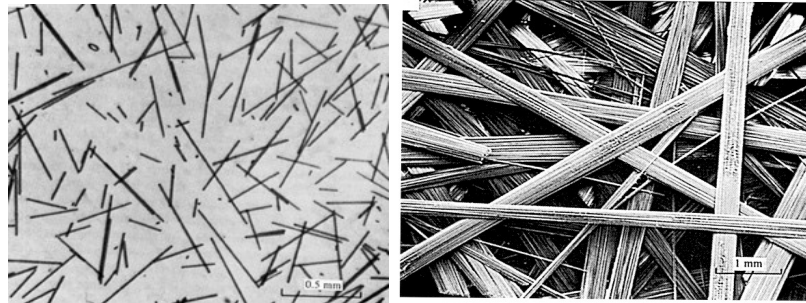

Elasticité des matériaux anisotropes

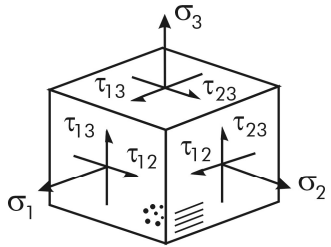

Propriétés élastiques
du composite

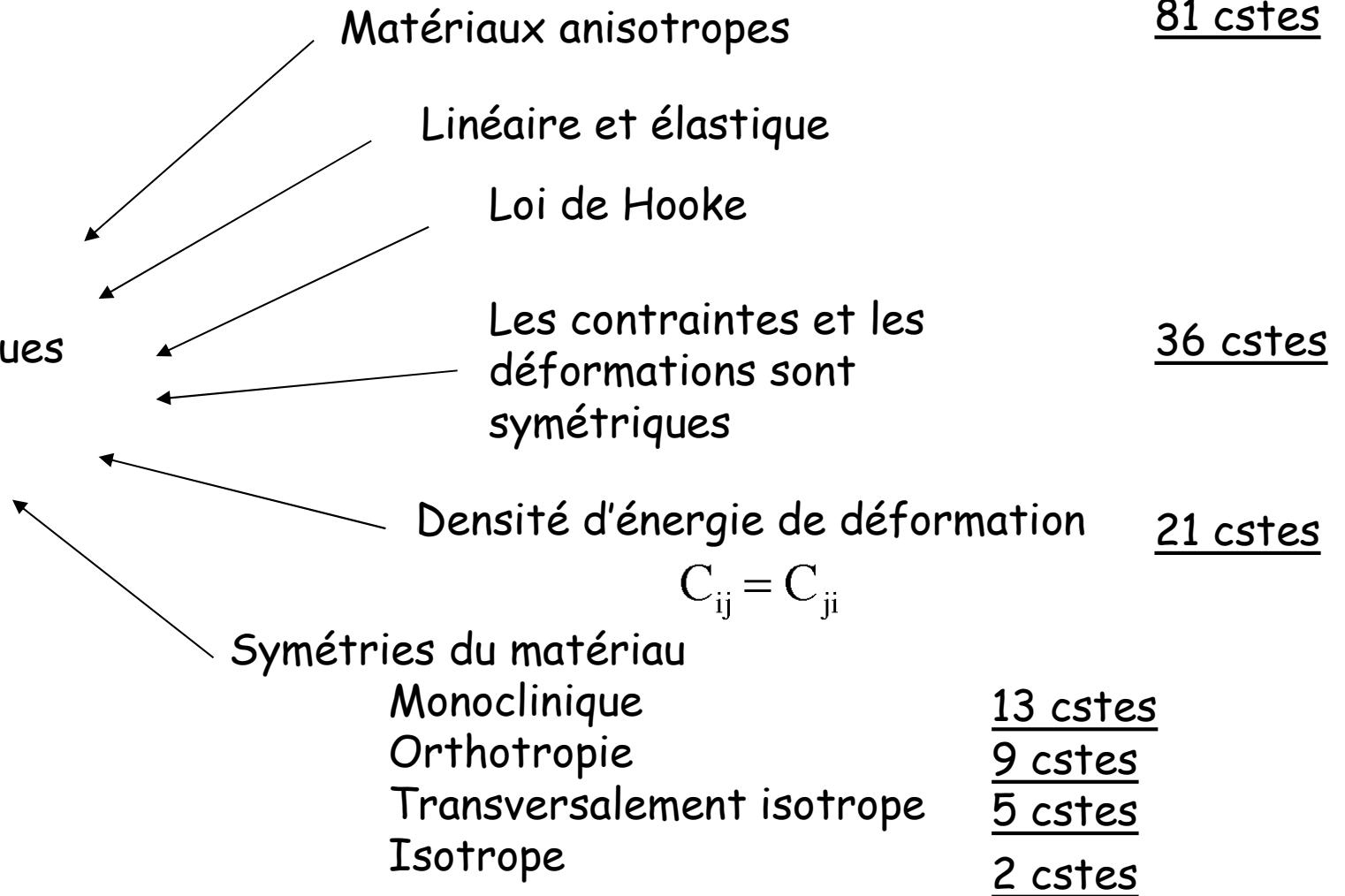

Anisotrope et élastique

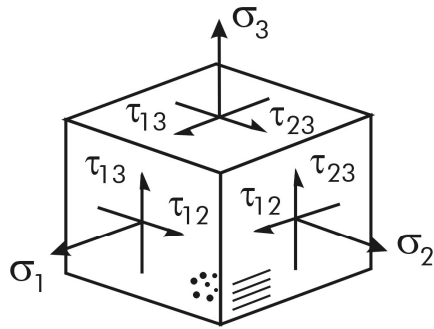

$$\sigma_{ij} = f(\varepsilon_{kl})$$

Hypo: Linéaire et élastique (81)

$$\begin{bmatrix} \sigma_{11} \\ \sigma_{22} \\ \sigma_{33} \\ \tau_{12} \\ \dots \\ \dots \\ \dots \\ \dots \\ \dots \end{bmatrix} = \begin{bmatrix} C_{1111} & C_{1122} & C_{1133} & \dots & \dots & \dots & \dots & \dots & \dots \\ C_{2211} & C_{2222} & C_{2233} & & & & & & \\ \dots & & \dots & & & & & & \\ \dots & & & \dots & & & & & \\ \dots & & & & \dots & & & & \\ \dots & & & & & \dots & & & \\ \dots & & & & & & \dots & & \\ \dots & & & & & & & \dots & \\ \dots & & & & & & & & \dots \end{bmatrix} \begin{bmatrix} \varepsilon_{11} \\ \varepsilon_{22} \\ \varepsilon_{33} \\ \varepsilon_{12} \\ \dots \\ \dots \\ \dots \\ \dots \end{bmatrix}$$

Tenseurs symétriques

Les contraintes et les déformations sont symétriques (36)

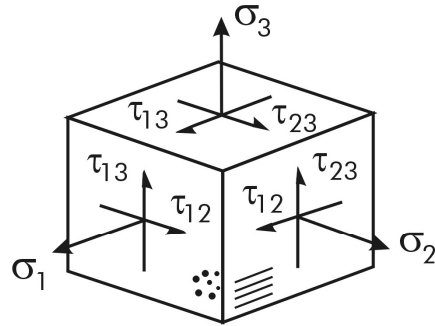

$$\tau_{12} = \tau_{21} \text{ etc}$$

Notation contractée

$$\sigma_{11} \rightsquigarrow \sigma_1 \text{ etc}$$

$$C_{ijkl} \rightsquigarrow C_{ij}$$

Densité d'énergie de déformation (21)

$$W = \frac{1}{2} \sigma_i \varepsilon_i$$

$$\frac{\partial^2 W}{\partial \varepsilon_i \partial \varepsilon_j} = C_{ij}$$

$$\sigma_i = C_{ij} \varepsilon_j$$

'' ''

C_{ij} est symétrique

$$\frac{\partial^2 W}{\partial \varepsilon_j \partial \varepsilon_i} = C_{ji}$$

$$\begin{bmatrix} \sigma_1 \\ \sigma_2 \\ \sigma_3 \\ \sigma_4 \\ \sigma_5 \\ \sigma_6 \end{bmatrix} = \begin{bmatrix} C_{11} & C_{12} & C_{13} & C_{14} & C_{15} & C_{16} \\ C_{21} & C_{22} & C_{23} & C_{24} & C_{25} & C_{26} \\ C_{31} & C_{32} & C_{33} & C_{34} & C_{35} & C_{36} \\ C_{41} & C_{42} & C_{43} & C_{44} & C_{45} & C_{46} \\ C_{51} & C_{52} & C_{53} & C_{54} & C_{55} & C_{56} \\ C_{61} & C_{62} & C_{63} & C_{64} & C_{65} & C_{66} \end{bmatrix} \begin{bmatrix} \varepsilon_1 \\ \varepsilon_2 \\ \varepsilon_3 \\ \varepsilon_4 \\ \varepsilon_5 \\ \varepsilon_6 \end{bmatrix}$$

6 x 6

Symétries des matériaux

Monocliniques (13)

Orthotropes (9)

$$[C] = \begin{bmatrix} C_{11} & C_{12} & C_{13} & 0 & 0 & 0 \\ C_{12} & C_{22} & C_{23} & 0 & 0 & 0 \\ C_{13} & C_{23} & C_{33} & 0 & 0 & 0 \\ 0 & 0 & 0 & C_{44} & 0 & 0 \\ 0 & 0 & 0 & 0 & C_{55} & 0 \\ 0 & 0 & 0 & 0 & 0 & C_{66} \end{bmatrix}$$

Transversalement isotropes (5) $2 \leftrightarrow 3$ $C_{22} = C_{33}$ etc

Isotropes(2)

Constantes de l'ingénieur

$$\{\sigma\} = [C]\{\varepsilon\}$$

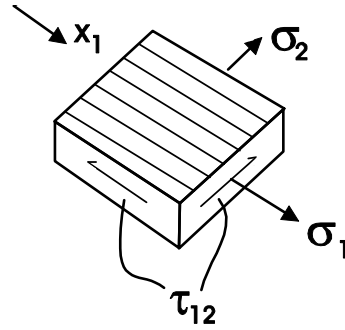

$$\{\varepsilon\} = [S]\{\sigma\}$$

**Test A: que σ_1
autres contraintes = 0**

$$\varepsilon_1 = \frac{\sigma_1}{E_1} \quad \nu_{ij} = -\frac{\varepsilon_j}{\varepsilon_i}$$

$$\varepsilon_2 = -\nu_{12}\varepsilon_1 = -\nu_{12} \frac{\sigma_1}{E_1}$$

$$\varepsilon_3 = -\nu_{13}\varepsilon_1 = -\nu_{13} \frac{\sigma_1}{E_1}$$

$$\gamma_{12} = \gamma_{23} = \gamma_{13} = 0$$

**Test B: que σ_2
autres contraintes = 0**

$$\varepsilon_2 = \frac{\sigma_2}{E_2}$$

$$\varepsilon_1 = -\nu_{21}\varepsilon_2 = -\nu_{21} \frac{\sigma_2}{E_2}$$

$$\varepsilon_3 = \dots$$

$$\gamma_{12} = \gamma_{23} = \gamma_{13} = 0$$

**Test C: que τ_{12}
autres contraintes = 0**

$$\gamma_{12} = \frac{\tau_{12}}{G_{12}}$$

$$\varepsilon_1 = \varepsilon_2 = \varepsilon_3 = \gamma_{23} = \gamma_{13} = 0$$

Constantes de l'ingénieur

$$\varepsilon_1 = \frac{\sigma_1}{E_1}$$

$$\varepsilon_1 = -\nu_{21}\varepsilon_2 = -\nu_{21}\frac{\sigma_2}{E_2}$$

$$\begin{Bmatrix} \varepsilon_1 \\ \varepsilon_2 \\ \varepsilon_3 \\ \gamma_{23} \\ \gamma_{31} \\ \gamma_{12} \end{Bmatrix} = \begin{bmatrix} \frac{1}{E_1} & -\frac{\nu_{21}}{E_2} & -\frac{\nu_{31}}{E_3} & 0 & 0 & 0 \\ -\frac{\nu_{12}}{E_1} & \frac{1}{E_2} & -\frac{\nu_{32}}{E_3} & 0 & 0 & 0 \\ -\frac{\nu_{13}}{E_1} & -\frac{\nu_{23}}{E_2} & \frac{1}{E_3} & 0 & 0 & 0 \\ 0 & 0 & 0 & \frac{1}{G_{23}} & 0 & 0 \\ 0 & 0 & 0 & 0 & \frac{1}{G_{31}} & 0 \\ 0 & 0 & 0 & 0 & 0 & \frac{1}{G_{12}} \end{bmatrix} \begin{Bmatrix} \sigma_1 \\ \sigma_2 \\ \sigma_3 \\ \tau_{23} \\ \tau_{31} \\ \tau_{12} \end{Bmatrix}$$

$$\{\varepsilon\} = [S]\{\sigma\}$$

$$\gamma_{12} = \frac{\tau_{12}}{G_{12}}$$

$$S_{12} = S_{21} \text{ donc } -\frac{\nu_{21}}{E_2} = -\frac{\nu_{12}}{E_1} \quad \text{pour un matériau orthotrope}$$

Matériaux orthotropes en contraintes planes (3=0)

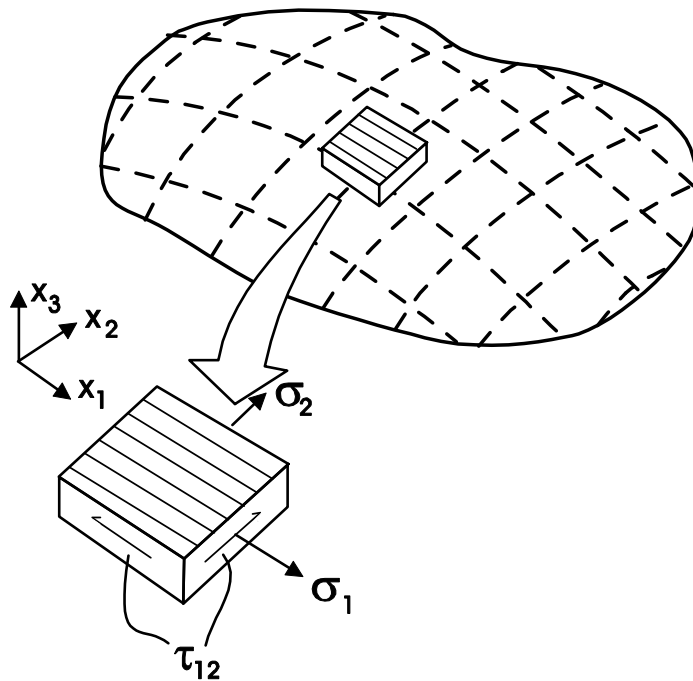

$$[S_{ij}] = \begin{bmatrix} S_{11} & S_{12} & 0 \\ S_{12} & S_{22} & 0 \\ 0 & 0 & S_{66} \end{bmatrix} = \begin{bmatrix} 1/E_1 & -\nu_{21}/E_2 & 0 \\ -\nu_{12}/E_1 & 1/E_2 & 0 \\ 0 & 0 & 1/G_{12} \end{bmatrix}$$

$$\begin{bmatrix} \sigma_1 \\ \sigma_2 \\ \tau_{12} \end{bmatrix} = \begin{bmatrix} Q_{11} & Q_{12} & 0 \\ Q_{12} & Q_{22} & 0 \\ 0 & 0 & Q_{66} \end{bmatrix} \begin{bmatrix} \varepsilon_1 \\ \varepsilon_2 \\ \gamma_{12} \end{bmatrix}$$

$$Q_{11} = \frac{E_1}{(1-\nu_{12}\nu_{21})}$$

$$Q_{22} = \frac{E_2}{(1-\nu_{12}\nu_{21})}$$

$$Q_{12} = \frac{\nu_{12}E_2}{(1-\nu_{12}\nu_{21})} = \frac{\nu_{21}E_1}{(1-\nu_{12}\nu_{21})}$$

$$Q_{66} = G_{12}$$

Importance de l'orientation des fibres

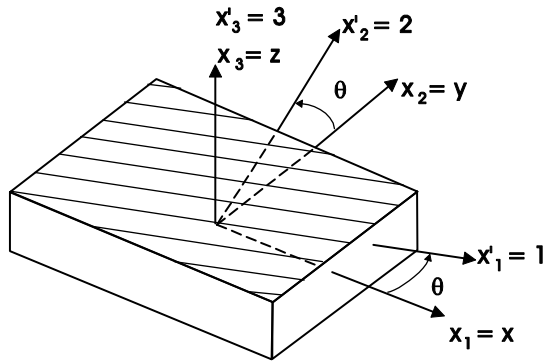

$$m = \cos, n = \sin$$

$$[T] = \begin{bmatrix} m^2 & n^2 & 2mn \\ n^2 & m^2 & -2mn \\ -mn & mn & m^2 - n^2 \end{bmatrix}$$

$$\begin{bmatrix} \sigma_1 \\ \sigma_2 \\ \tau_{12} \end{bmatrix} = [T] \begin{bmatrix} \sigma_x \\ \sigma_y \\ \tau_{xy} \end{bmatrix}$$

$$\begin{bmatrix} \sigma_x \\ \sigma_y \\ \tau_{xy} \end{bmatrix} = [T]^{-1} \begin{bmatrix} \sigma_1 \\ \sigma_2 \\ \tau_{12} \end{bmatrix} = [T]^{-1} [Q] \begin{bmatrix} \varepsilon_1 \\ \varepsilon_2 \\ \gamma_{12} \end{bmatrix} = [T]^{-1} [Q] [T] \begin{bmatrix} \varepsilon_x \\ \varepsilon_y \\ \gamma_{xy} \end{bmatrix} = [\bar{Q}] \begin{bmatrix} \varepsilon_x \\ \varepsilon_y \\ \gamma_{xy} \end{bmatrix}$$

$$\begin{bmatrix} \sigma_x \\ \sigma_y \\ \tau_{xy} \end{bmatrix} = \begin{bmatrix} \bar{Q}_{11} \\ \bar{Q}_{12} \\ \bar{Q}_{16} \end{bmatrix} \begin{bmatrix} \varepsilon_x \\ \varepsilon_y \\ \gamma_{xy} \end{bmatrix} + \begin{bmatrix} \bar{Q}_{12} \\ \bar{Q}_{22} \\ \bar{Q}_{26} \end{bmatrix} \begin{bmatrix} \varepsilon_x \\ \varepsilon_y \\ \gamma_{xy} \end{bmatrix} + \begin{bmatrix} \bar{Q}_{16} \\ \bar{Q}_{26} \\ \bar{Q}_{66} \end{bmatrix} \begin{bmatrix} \varepsilon_x \\ \varepsilon_y \\ \gamma_{xy} \end{bmatrix}$$

$$\bar{Q}_{11} = m^4 Q_{11} + 2m^2 n^2 (Q_{12} + 2Q_{66}) + n^4 Q_{22}$$

$$\bar{Q}_{21} = \bar{Q}_{12} = m^2 n^2 (Q_{11} + Q_{22} - 4Q_{66}) + Q_{12} (m^4 + n^4)$$

$$\bar{Q}_{22} = n^4 Q_{11} + 2m^2 n^2 (Q_{12} + 2Q_{66}) + m^4 Q_{22}$$

$$\bar{Q}_{16} = m^3 n (Q_{11} - Q_{12}) + mn^3 (Q_{12} - Q_{22}) - 2mn (m^2 - n^2) Q_{66}$$

$$\bar{Q}_{26} = mn^3 (Q_{11} - Q_{12}) + m^3 n (Q_{12} - Q_{22}) + 2mn (m^2 - n^2) Q_{66}$$

$$\bar{Q}_{66} = m^2 n^2 (Q_{11} + Q_{22} - 2Q_{12} - 2Q_{66}) + (m^4 + n^4) Q_{66}$$

Matériaux orthotropes en contraintes planes

$$\begin{bmatrix} \varepsilon_x \\ \varepsilon_y \\ \gamma_{xy} \end{bmatrix} = \begin{bmatrix} \bar{S}_{11} & \bar{S}_{12} & \bar{S}_{16} \\ \bar{S}_{12} & \bar{S}_{22} & \bar{S}_{26} \\ \bar{S}_{16} & \bar{S}_{26} & \bar{S}_{66} \end{bmatrix} \begin{bmatrix} \sigma_x \\ \sigma_y \\ \tau_{xy} \end{bmatrix}$$

$$\bar{S}_{11} = m^4 S_{11} + m^2 n^2 (2S_{12} + S_{66}) + n^4 S_{22}$$

$$\bar{S}_{21} = \bar{S}_{12} = m^2 n^2 (S_{11} + S_{22} - S_{66}) + S_{12} (m^4 + n^4)$$

$$\bar{S}_{22} = n^4 S_{11} + m^2 n^2 (2S_{12} + S_{66}) + m^4 S_{22}$$

$$\bar{S}_{16} = 2m^3 n (S_{11} - S_{12}) + 2mn^3 (S_{12} - S_{22}) - mn(m^2 - n^2) S_{66}$$

$$\bar{S}_{26} = 2mn^3 (S_{11} - S_{12}) + 2m^3 n (S_{12} - S_{22}) - mn(m^2 - n^2) S_{66}$$

$$\bar{S}_{66} = 4m^2 n^2 (S_{11} - S_{12}) + 4m^2 n^2 (S_{12} - S_{22}) - (m^2 - n^2)^2 S_{66}$$

De la théorie des stratifiés aux outils de conception

Théorie des stratifiés

Symétrie des stratifiés

Effets de couplage

Propriétés effectives

Guides pour la conception

Elasticité des stratifiés

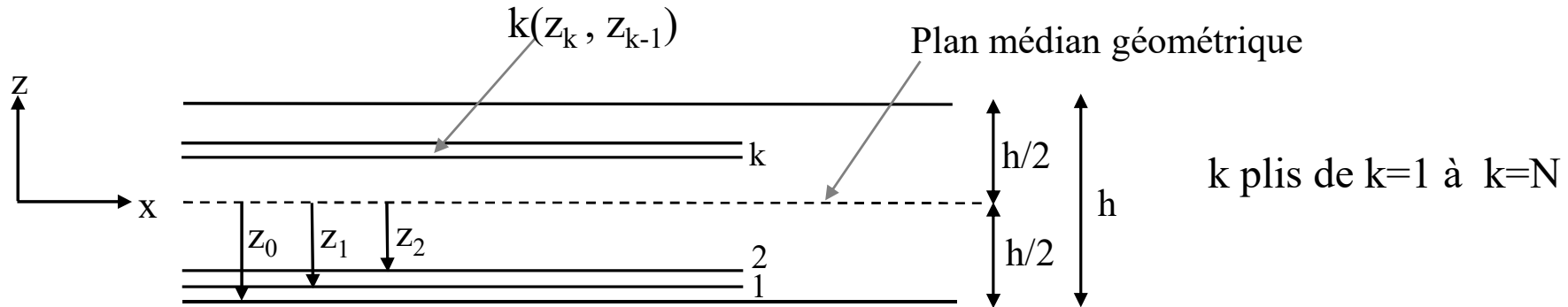

(H) CLT: Classical Laminate Theory

- Linéaire élastique
- Orthotrope
- Membrane, contraintes planes ($\sigma_3, \varepsilon_3 = 0$) \equiv pas de déformation selon l'axe z , seulement déformation hors du plan
- Hyp. de Kirchoff

ε_x

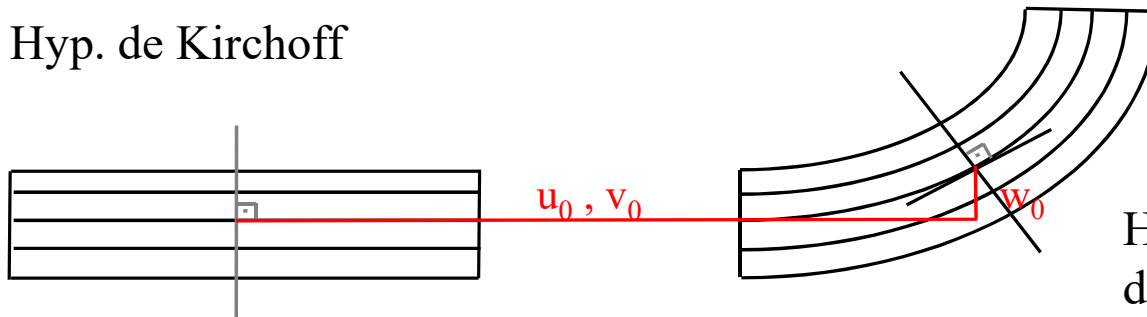

Hyp: Adhésion parfaite entre les plis, déformation selon $z = 0$
 si non plus en contrainte plane et des termes sup sont à ajouter dans les prochaines équations

Elasticité des stratifiés

- Déplacement de tout point de cote z

$$u = u_0 - z \frac{\partial w_0}{\partial x}$$

$$v = v_0 - z \frac{\partial w_0}{\partial y}$$

$$w = w_0$$

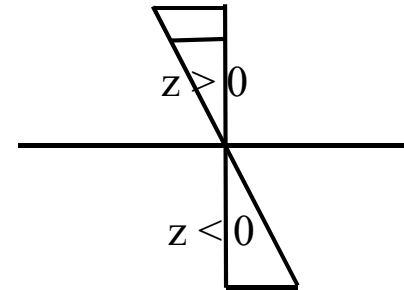

- Déformation

$$\varepsilon_x = \varepsilon_x^0 - z \frac{\partial^2 w_0}{\partial x^2}$$

- κ : courbure

$$\varepsilon_y = \varepsilon_y^0 - z \frac{\partial^2 w_0}{\partial y^2}$$

$$\gamma_{xy} = \gamma_{xy}^0 - 2z \frac{\partial^2 w_0}{\partial x \partial y}$$

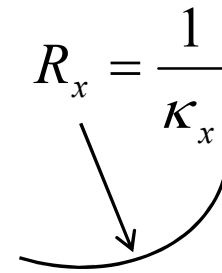

$$\{\varepsilon\} = \{\varepsilon^0\} + z\{\kappa\}$$

Elasticité des stratifiés

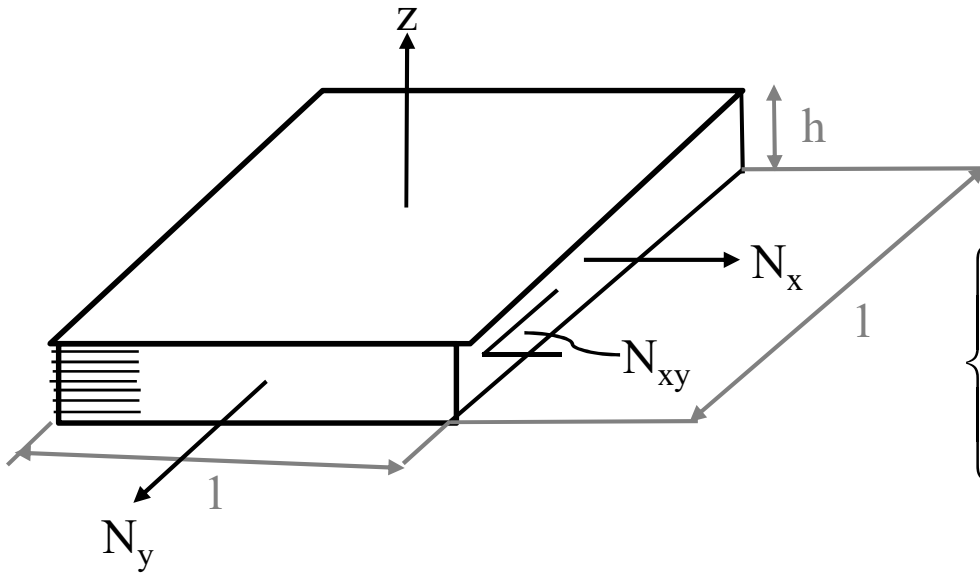

$$S = h \cdot 1 = h$$

largeur unitaire

$$\sigma = \frac{N}{S} = \frac{N}{h}$$

$$\begin{Bmatrix} \sigma_x \\ \sigma_y \\ \sigma_{xy} \end{Bmatrix} = \begin{bmatrix} & & \\ & & \\ & & \end{bmatrix} \bar{Q} \begin{Bmatrix} \varepsilon_x \\ \varepsilon_y \\ \gamma_{xy} \end{Bmatrix}$$

$$\begin{Bmatrix} \varepsilon_x^0 \\ \varepsilon_y^0 \\ \gamma_{xy}^0 \end{Bmatrix} + z \begin{Bmatrix} K_x \\ K_y \\ K_{xy} \end{Bmatrix}$$

$$\rightarrow [\sigma] = [\bar{Q}] (\{\varepsilon^0\} + z \{K\})$$

Elasticité des stratifiés

$$\begin{aligned}
 \begin{bmatrix} N_x \\ N_y \\ N_{xy} \end{bmatrix} &= \int_{-h/2}^{h/2} \begin{bmatrix} \sigma_x \\ \sigma_y \\ \sigma_{xy} \end{bmatrix} dz = \int_{-h/2}^{h/2} [\bar{Q}] \left([\varepsilon^0] + z [\kappa] \right) dz \\
 &= \sum_{k=1}^N \int_{z_{k-1}}^{z_k} \underbrace{[\bar{Q}]_k}_{\neq f(z)} \left([\varepsilon^0] + z [\kappa] \right) dz \\
 &= \sum_{k=1}^N \underbrace{[\bar{Q}]_k}_{\rightarrow [A]} [\varepsilon^0] \underbrace{(z_k - z_{k-1})}_{\rightarrow [B]} + \underbrace{[\bar{Q}]_k}_{\rightarrow [B]} [\kappa] \underbrace{\frac{z_k^2 - z_{k-1}^2}{2}}_{\rightarrow [A]} \\
 \begin{bmatrix} N_x \\ N_y \\ N_{xy} \end{bmatrix} &= [A] [\varepsilon^0] + [B] [\kappa]
 \end{aligned}$$

Elasticité des stratifiés

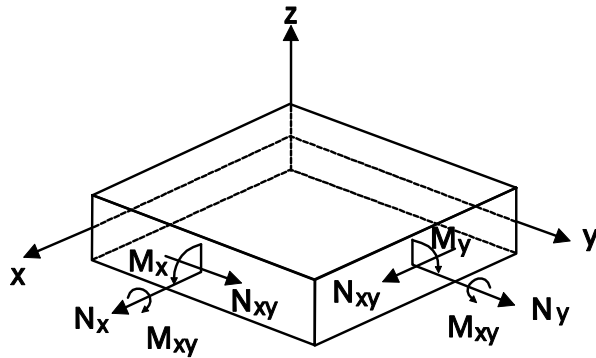

$$\begin{bmatrix} \mathbf{N} \\ \mathbf{M} \end{bmatrix} = \begin{bmatrix} \mathbf{A} & \mathbf{B} \\ \mathbf{B} & \mathbf{D} \end{bmatrix} \begin{bmatrix} \boldsymbol{\varepsilon}^0 \\ \boldsymbol{\kappa} \end{bmatrix}$$

$$\begin{bmatrix} N_x \\ N_y \\ N_{xy} \end{bmatrix} = \begin{bmatrix} A_{11} & A_{12} & A_{16} \\ A_{12} & A_{22} & A_{26} \\ A_{16} & A_{26} & A_{66} \end{bmatrix} \begin{bmatrix} \varepsilon_x^0 \\ \varepsilon_y^0 \\ \gamma_{xy}^0 \end{bmatrix} + \begin{bmatrix} B_{11} & B_{12} & B_{16} \\ B_{12} & B_{22} & B_{26} \\ B_{16} & B_{26} & B_{66} \end{bmatrix} \begin{bmatrix} K_x \\ K_y \\ K_{xy} \end{bmatrix}$$

$$\begin{bmatrix} M_x \\ M_y \\ M_{xy} \end{bmatrix} = \begin{bmatrix} B_{11} & B_{12} & B_{16} \\ B_{12} & B_{22} & B_{26} \\ B_{16} & B_{26} & B_{66} \end{bmatrix} \begin{bmatrix} \varepsilon_x^0 \\ \varepsilon_y^0 \\ \gamma_{xy}^0 \end{bmatrix} + \begin{bmatrix} D_{11} & D_{12} & D_{16} \\ D_{12} & D_{22} & D_{26} \\ D_{16} & D_{26} & D_{66} \end{bmatrix} \begin{bmatrix} K_x \\ K_y \\ K_{xy} \end{bmatrix}$$

$$A_{ij} = \sum_{k=1}^N (\overline{Q}_{ij})_k (z_k - z_{k-1})$$

$$B_{ij} = \frac{1}{2} \sum_{k=1}^N (\overline{Q}_{ij})_k (z_k^2 - z_{k-1}^2)$$

$$D_{ij} = \frac{1}{3} \sum_{k=1}^N (\overline{Q}_{ij})_k (z_k^3 - z_{k-1}^3)$$

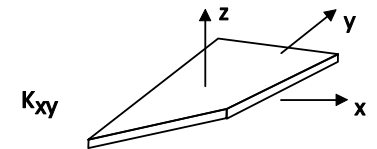
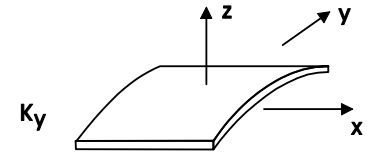
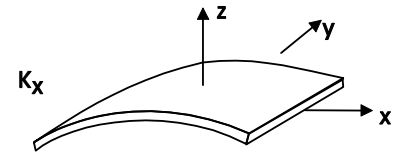

Couplages

$$\begin{bmatrix} N_x \\ N_y \\ N_{xy} \end{bmatrix} = \begin{bmatrix} A_{11} & A_{12} & A_{16} \\ A_{12} & A_{22} & A_{26} \\ A_{16} & A_{26} & A_{66} \end{bmatrix} \begin{bmatrix} \varepsilon_x^0 \\ \varepsilon_y^0 \\ \gamma_{xy}^0 \end{bmatrix} + \begin{bmatrix} B_{11} & B_{12} & B_{16} \\ B_{12} & B_{22} & B_{26} \\ B_{16} & B_{26} & B_{66} \end{bmatrix} \begin{bmatrix} K_x \\ K_y \\ K_{xy} \end{bmatrix}$$

$$\begin{bmatrix} M_x \\ M_y \\ M_{xy} \end{bmatrix} = \begin{bmatrix} B_{11} & B_{12} & B_{16} \\ B_{12} & B_{22} & B_{26} \\ B_{16} & B_{26} & B_{66} \end{bmatrix} \begin{bmatrix} \varepsilon_x^0 \\ \varepsilon_y^0 \\ \gamma_{xy}^0 \end{bmatrix} + \begin{bmatrix} D_{11} & D_{12} & D_{16} \\ D_{12} & D_{22} & D_{26} \\ D_{16} & D_{26} & D_{66} \end{bmatrix} \begin{bmatrix} K_x \\ K_y \\ K_{xy} \end{bmatrix}$$

Elasticité des stratifiés

$$\begin{bmatrix} \varepsilon^0 \\ \kappa \end{bmatrix} = \begin{bmatrix} a & b \\ c & d \end{bmatrix} \begin{bmatrix} N \\ M \end{bmatrix}$$

$$[a] = [A^*] - [B^*][D^*]^{-1}[C^*]$$

$$[b] = [B^*][D^*]^{-1} \quad [c] = -[D^*]^{-1}[C^*] \quad [d] = [D^*]^{-1}$$

$$[A^*] = [A]^{-1} \quad [B^*] = -[A]^{-1}[B] \quad [C^*] = [B][A]^{-1} \quad [D^*] = [D] - [B][A]^{-1}[B]$$

Exercice



$$[A] =$$

$$[B] =$$

$$[D] =$$



$$[A] =$$

$$[B] =$$

$$[D] =$$

Notations et symétries des stratifiés

$$[0/0/0/0/0/0] = [0_6]$$

$$[0/90/90/0] = [0/90]_s$$

$$[0/90/0] = [0/\overline{90}]_s$$

$$[+45/-45/-45/45] = [\pm 45]_s$$

$$[30/-30/30/-30/-30/30/-30/30] = [\pm 30]_{2s}$$

$$[30/-30/30/-30/30/-30/30/-30] = [\pm 30]_4$$

$$[0/45/-45/-45/45/0] = [0/\pm 45]_s$$

$$[0/0/45/-45/0/0/0/0/-45/45/0/0] = [0_2/\pm 45/0_2]_s$$

$$[0/15/-15/15/-15/0] = [0/\pm 15/\pm 15/0] = [0/(\pm 15)_2/0]$$

$$[0^K/0^K/45^C/-45^C/90^G/-45^C/45^C/0^K/0^K] = [0_2^K/\pm 45^C/\overline{90^G}]_s$$

Symétries des stratifiés

- Stratifiés symétriques

Pas de couplage entre extension et flexion

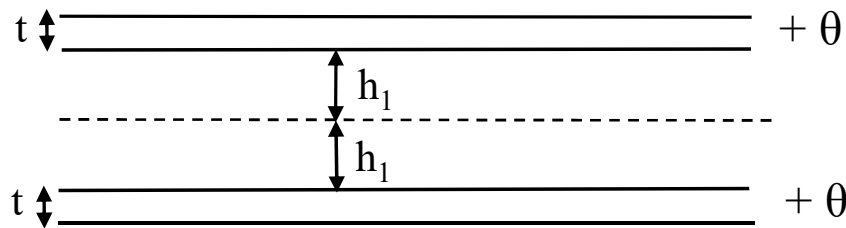

$$B_{ij} = 0$$

- Stratifiés balancés

Pas de couplage entre extension et cisaillement

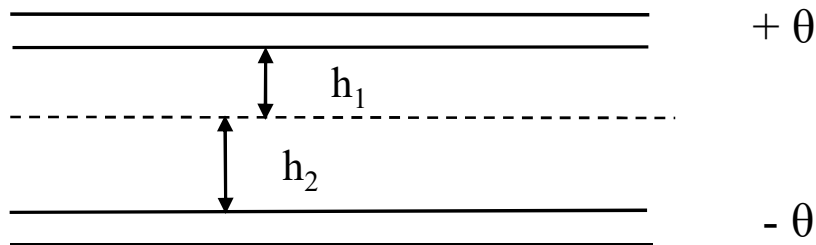

$$A_{16} = A_{26} = 0$$

- Balancé + symétrique

$$A_{16} = A_{26} = 0 \quad B_{ij} = 0$$

Symétries des stratifiés

- Antisymétriques

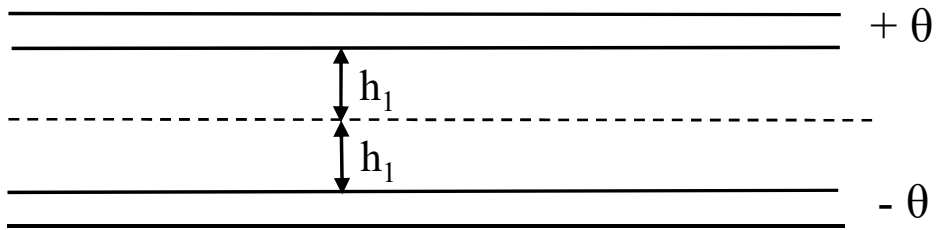

$$D_{16} = D_{26} = 0$$

Pas de couplage entre flexion et torsion

- Croisé, ``crossply laminate``

ssi à 0° et 90°

$$B_{12} = B_{16} = B_{26} = 0$$

- $(0, +45, -45, 90)$

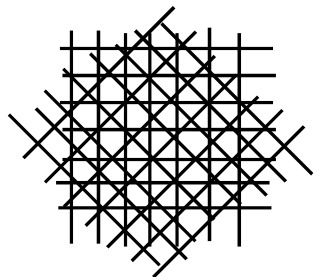

Quasi-isotrope

$$A_{11} \approx A_{22}$$

$(0, \pm 60)$

Stratifiés symétriques balancés

Laminate	A_{11} (MN/m)	A_{22} (MN/m)	G_{xy} (GPa)
$[90_8]_s$	11.09	153.28	2.29
$[0/90_7]_s$	28.86	135.51	2.29
$[0_2/90_6]_s$	46.64	117.73	2.29
$[0_3/90_5]_s$	64.41	99.96	2.29
$[0_4/90_4]_s$	82.18	82.18	2.29
$[0_5/90_3]_s$	99.96	64.41	2.29
$[0_6/90_2]_s$	117.73	46.64	2.29
$[0_7/90]_s$	135.51	28.86	2.29
$[0_8]_s$	153.28	11.09	2.29
$[\pm 45/90_6]_s$	20.21	126.85	6.62
$[\pm 45/0/90_5]_s$	37.98	109.08	6.62
$[\pm 45/0_2/90_4]_s$	55.76	91.31	6.62
$[\pm 45/0_3/90_3]_s$	73.53	73.53	6.62
$[\pm 45/0_4/90_2]_s$	91.31	55.76	6.62
$[\pm 45/0_5/90]_s$	109.08	37.98	6.62
$[\pm 45/0_6]_s$	126.85	20.21	6.62
$[\pm 45_2/90_4]_s$	29.33	100.43	10.95
$[\pm 45_2/0/90_3]_s$	47.11	82.65	10.95
$[\pm 45_2/0_2/90_2]_s$	64.88	64.88	10.95
$[\pm 45_2/0_3/90]_s$	82.65	47.11	10.95
$[\pm 45_2/0_4]_s$	100.43	29.33	10.95
$[\pm 45_3/90_2]_s$	38.45	74.00	15.27 F
$[\pm 45_3/0/90]_s$	56.23	56.23	15.27 F
$[\pm 45_3/0_2]_s$	74.00	38.45	15.28 F
$[\pm 45_4]_s$	47.58	47.58	19.60 F

Dimensionnement : propriétés effectives

Efforts connus

$$\begin{bmatrix} N_x \\ N_y \\ N_{xy} \end{bmatrix} = \begin{bmatrix} A_{11} & A_{12} & A_{16} \\ A_{12} & A_{22} & A_{26} \\ A_{16} & A_{26} & A_{66} \end{bmatrix} \begin{bmatrix} \varepsilon_x^0 \\ \varepsilon_y^0 \\ \gamma_{xy}^0 \end{bmatrix}$$

h = épaisseur du stratifié

Contraintes globales moyennes (fictives)

$$\begin{bmatrix} \sigma_x \\ \sigma_y \\ \tau_{xy} \end{bmatrix} = 1/h \begin{bmatrix} N_x \\ N_y \\ N_{xy} \end{bmatrix} = 1/h \begin{bmatrix} A_{11} & A_{12} & A_{16} \\ A_{12} & A_{22} & A_{26} \\ A_{16} & A_{26} & A_{66} \end{bmatrix} \begin{bmatrix} \varepsilon_x^0 \\ \varepsilon_y^0 \\ \gamma_{xy}^0 \end{bmatrix}$$

$$\frac{1}{h} A_{ij} = \sum_{k=1}^N (\overline{Q_{ij}})_k \frac{\text{épaisseur}_k}{h} = \sum_{k=1}^N (\overline{Q_{ij}})_k \text{pourcentage}_k$$

Inverser pour obtenir des modules effectifs... et les déformations

$$\begin{bmatrix} \varepsilon_x \\ \varepsilon_y \\ \gamma_{xy} \end{bmatrix} = h \cdot \begin{bmatrix} A_{11} & A_{12} & A_{16} \\ A_{12} & A_{22} & A_{26} \\ A_{16} & A_{26} & A_{66} \end{bmatrix}^{-1} \begin{bmatrix} \sigma_x \\ \sigma_y \\ \tau_{xy} \end{bmatrix} = \begin{bmatrix} \frac{1}{E_x} & -\frac{\nu_{xy}}{E_x} & 0 \\ -\frac{\nu_{yx}}{E_y} & \frac{1}{E_y} & 0 \\ 0 & 0 & \frac{1}{G_{xy}} \end{bmatrix} \begin{bmatrix} \sigma_x \\ \sigma_y \\ \tau_{xy} \end{bmatrix}$$

Propriétés effectives

Si symétrique et balancé

$$\begin{bmatrix} N_x \\ N_y \\ N_{xy} \end{bmatrix} + \begin{bmatrix} N_x^T \\ N_y^T \\ 0 \end{bmatrix} = \begin{bmatrix} A_{11} & A_{12} & 0 \\ A_{12} & A_{22} & 0 \\ 0 & 0 & A_{66} \end{bmatrix} \begin{bmatrix} \varepsilon_x^0 \\ \varepsilon_y^0 \\ \gamma_{xy}^0 \end{bmatrix}$$

$$\begin{bmatrix} \varepsilon_x^0 \\ \varepsilon_y^0 \\ \gamma_{xy}^0 \end{bmatrix} = \begin{bmatrix} a_{11} & a_{12} & 0 \\ a_{12} & a_{22} & 0 \\ 0 & 0 & a_{66} \end{bmatrix} \left\{ \begin{bmatrix} N_x \\ N_y \\ N_{xy} \end{bmatrix} + \begin{bmatrix} N_x^T \\ N_y^T \\ 0 \end{bmatrix} \right\}$$

Si seulement charge mécanique
et déformation uniforme
sur l'épaisseur

$$\varepsilon_x^0 = a_{11} N_x = \varepsilon_x \quad \sigma_x = \frac{N_x}{h} \quad \varepsilon_x = a_{11} h \sigma_x \quad E_x = \frac{\sigma_x}{\varepsilon_x} = \frac{1}{h a_{11}} \quad E_x = \frac{A_{11} A_{22} - A_{12}^2}{h A_{22}}$$

Propriétés effectives de l'ingénieur
à intégrer aux équations de la résistance des matériaux

$$\begin{bmatrix} \varepsilon_x \\ \varepsilon_y \\ \gamma_{xy} \end{bmatrix} = \begin{bmatrix} \frac{1}{E_x} & -\frac{\nu_{xy}}{E_x} & 0 \\ -\frac{\nu_{yx}}{E_y} & \frac{1}{E_y} & 0 \\ 0 & 0 & \frac{1}{G_{xy}} \end{bmatrix} \begin{bmatrix} \sigma_x \\ \sigma_y \\ \tau_{xy} \end{bmatrix}$$

Stratifié kevlar/époxyde

Guides de conception exp D. Gay

$V_f = 60\%$ de fibres en volume

épaisseur du pli : 0.13 mm

caractéristiques du pli : cf. paragraphe 3.3.3.

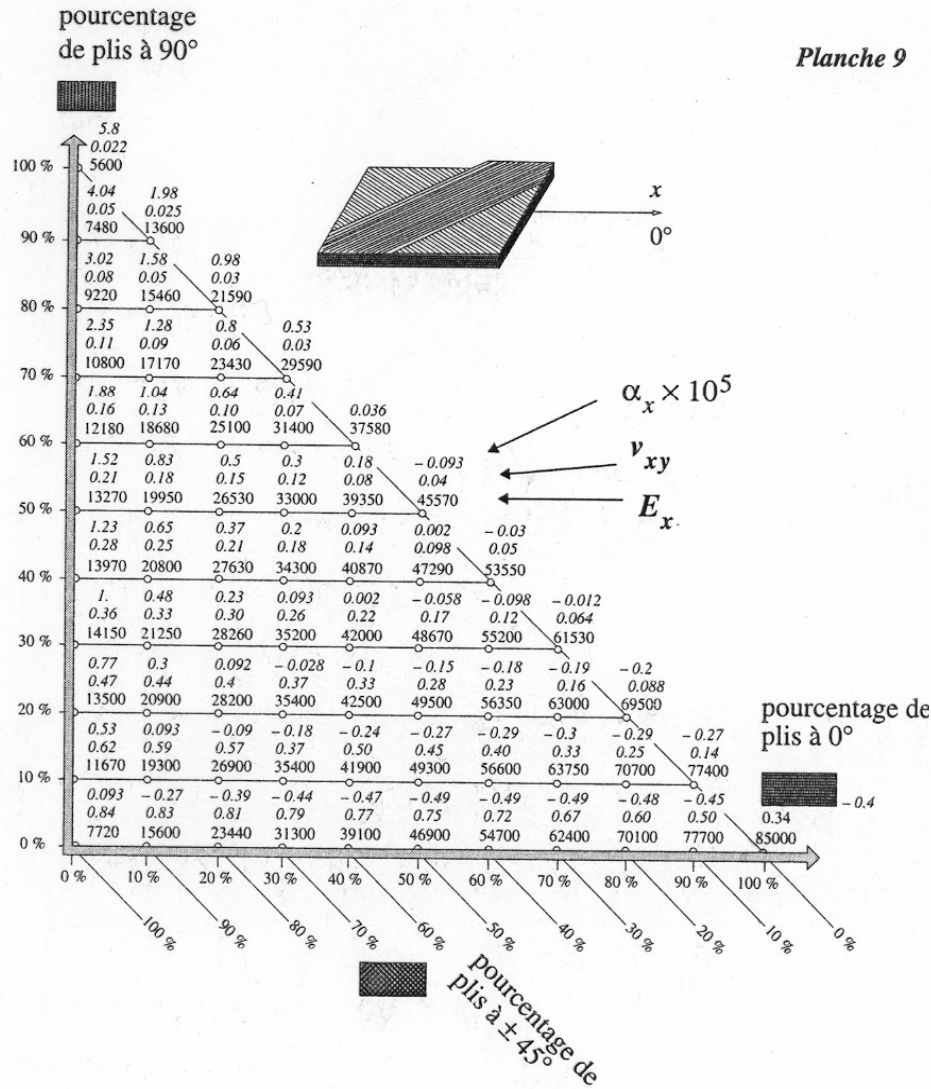

Stratifié carbone/époxyde

$V_f = 60\%$ de fibres en volume

épaisseur du pli : 0.13 mm

caractéristiques du pli : modules, contraintes de rupture : cf. paragraphe 3.3.3.

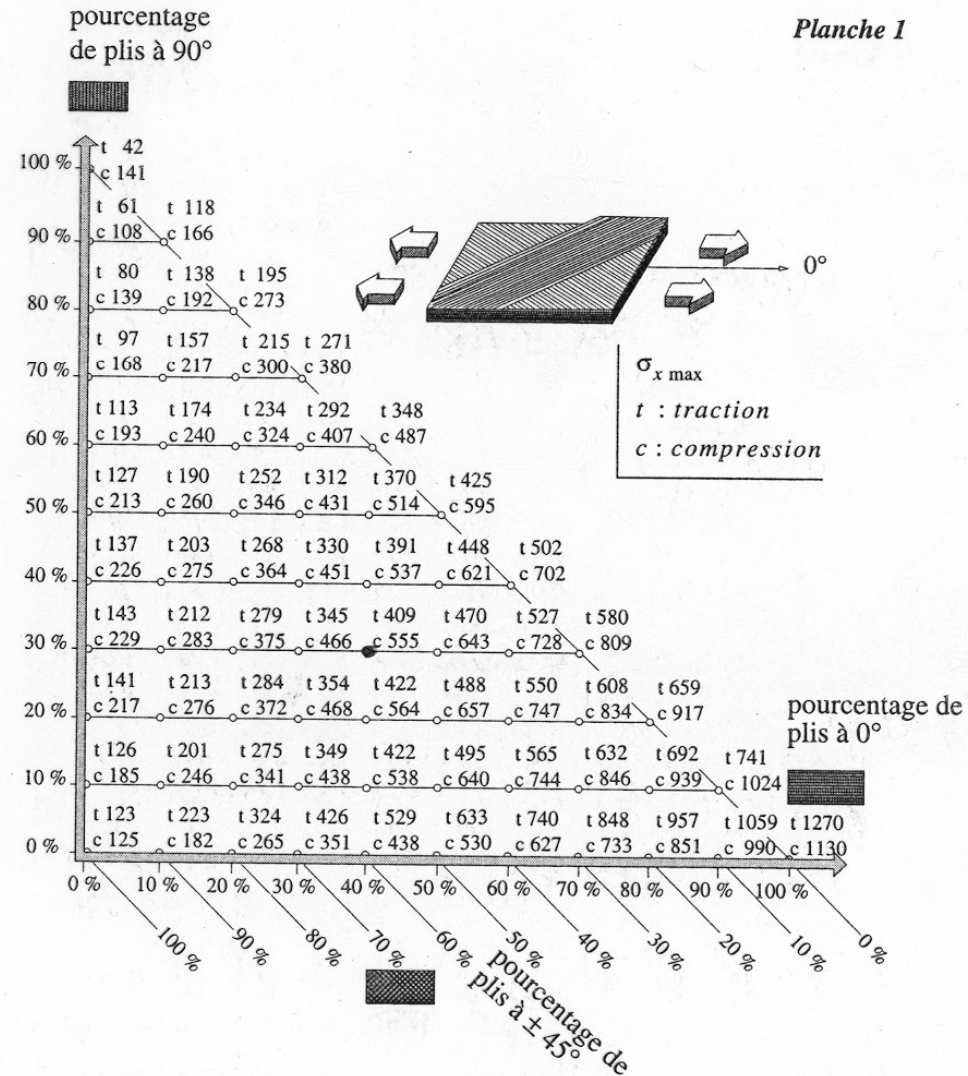

<https://altairhyperworks.com/product/ESAComp>

CoDA ou LAP sur <http://www.anaglyph.co.uk>

http://www.efunda.com/formulae/solid_mechanics/composites/calc_ufrp_abd_layout.cfm

CONNECTION à ESACOMP

Ouvrir l'application Omnissa Horizon Client.

Ouvrir vdi.epfl.ch

Accepter les clauses.

Connection au serveur via nom d'utilisateur et mdp Gaspar

Sélectionner STI-WINDOWS11

Sélectionner et démarrer le programme Altair ESAComp 2020

Accepter les créations de fichiers/liens personnels

Créer un dossier perso MonEsacomp sur le Desktop pour y sauver tous vos 'cases' et 'data' et que vous recopiez sur votre disque ou sur une clé pour sauvegarder et ré-ouvrir vos fichiers Esacomp pour les prochaines séances.